

## Instruction and operation manual

# S 600

## Portable compressed air purity analyzer



Dear Customer,  
thank you for choosing our product.

The operating instructions must be read in full and carefully observed before starting up the device. The manufacturer cannot be held liable for any damage which occurs as a result of non-observance or non-compliance with this manual.

Should the device be tampered with in any manner other than a procedure which is described and specified in the manual, the warranty is cancelled and the manufacturer is exempt from liability.

The device is destined exclusively for the described application.

SUTO iTEC GmbH offers no guarantee for the suitability for any other purpose. SUTO iTEC GmbH is also not liable for consequential damage resulting from the delivery, capability or use of this device.

## Table of contents

1. Safety instructions.....	4
2. Application.....	8
3. Features.....	8
4. Technical Data.....	9
4.1 General.....	9
4.2 Electrical data .....	10
4.3 Accuracy.....	10
5. Dimensions.....	11
6. Installation on site.....	14
6.1 Installation requirements.....	14
6.2 Connecting the isokinetic sampling device to the S 600 analyzer (Option).....	17
6.3 Using the S 600 without the isokinetic sampling device.....	19
6.4 Electrical connections on the S 600.....	19
6.5 Compressed air connections (In and outlet).....	20
7. Setup and configuration.....	21
8. Operation.....	22
8.1 Value screen.....	23
8.2 The menu.....	24
8.3 Symbol description in the status bar.....	24
8.4 Graphic view.....	25
8.6 Files.....	25
8.7 Service Info .....	26
8.8 System Setting.....	26
8.9 Report menu.....	27
9. Guided measurement.....	28
9.1 Guided measurement.....	29
10. Optional accessories.....	34
11. Maintenance.....	34
12. Disposal or waste.....	34
13. Warranty.....	35

## 1. Safety instructions

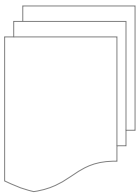

### **Please check if this instruction manual accords to the product type.**

Please observe all notes and instructions indicated in this manual. It contains essential information which have to be observed before and during installation, operation and maintenance. Therefore this instruction manual has to be read carefully by the technician as well as by the responsible user / qualified personnel.

This instruction manual has to be available at the operation site of the flow sensor at any time. In case of any obscurities or questions, regarding this manual or the product, please contact the manufacturer.



### **WARNING!**

#### **Compressed air!**

**Any contact with quickly escaping air or bursting parts of the compressed air system can lead to serious injuries or even death!**

- Do not exceed the maximum permitted pressure range (see sensors label).
- Only use pressure tight installation material.
- Avoid that persons get hit escaping air or bursting parts of the instrument.
- The system must be pressure less during maintenance work.

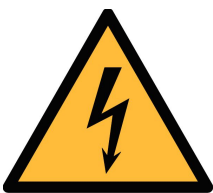

### • **WARNING!**

#### • **Voltage used for supply!**

• **Any contact with energized parts of the product, may lead to a electrical shock which can lead to serious injuries or even death!**

- Consider all regulations for electrical installations.
- The system must be disconnected from any power supply during maintenance work.

**WARNING!****Permitted operating parameters!**

**Observe the permitted operating parameters, any operation exceeding this parameters can lead to malfunctions and may lead to damage on the instrument or the system.**

- Do not exceed the permitted operating parameters.
- Make sure the product is operated in its permitted limitations.
- Do not exceed or undercut the permitted storage and operation temperature and pressure.

The product should be maintained and calibrated frequently, at least annually.

**General safety instructions**

- It is not allowed to use the product in explosive areas.
- Please observe the national regulations before/during installation and operation.

**Remarks**

- It is not allowed to disassemble the product.
- Always check the compressed air connectors in terms of stability and tightness.

**ATTENTION!****Measurement values can be affected by malfunction!**

**The product must be installed properly and frequently maintained, otherwise it may lead to wrong measurement values, which can lead to wrong results.**

- Always observe the direction of the flow when installing the sensor. The direction is indicated on the housing.
- Do not exceed the maximum operation temperature at the sensors tip.
- Avoid condensation on the sensor element as this will affect the accuracy enormously.

## **Storage and transportation**

- Make sure that the transportation temperature is between  $-10^{\circ}\text{C}$ ...  $70^{\circ}\text{C}$ .
- For transportation it is recommended to use the packaging which comes with the sensor.
- Please make sure that the storage temperature of the sensor is between  $-10^{\circ}\text{C}$ ...  $50^{\circ}\text{C}$ .
- Avoid direct UV and solar radiation during storage.
- For the storage the humidity has to be  $<90\%$ , no condensation.

**ATTENTION!****Equipment may get damaged!**

**Please make sure, that your measuring point is free of excessive contamination/dirt. This should be maintained before every measurement.**

- Observe the measuring point always before measurement if it is free of contamination like water drops, oil drops or other rough contaminations.
- Should water hit the inner electronics, the sensors could be seriously damaged.
- Check your measurement point with the enclosed test kit.

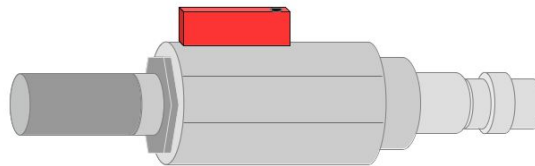
**ATTENTION!****Overpressure!**

**Remove always all protection caps before connecting the compressed air to the inlet.**

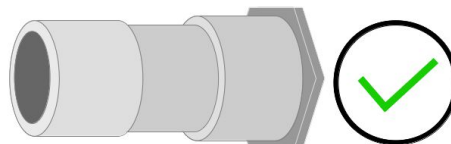
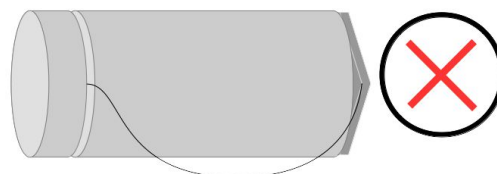

## 2. Application

The portable compressed air purity analyzer S 600 is able to measure, record and verify the quality parameters (particle quantity, dew point, temperature, pressure, oil vapor content) of a compressed air system.

The S 600 is not developed to be used in explosive areas. For the use in such areas, please contact the manufacturer.

The S 600 is mainly used in compressed air system as they are found in industrial environments.

## 3. Features

- High resolution 5" color touchscreen display and interface.
- USB port for coping the data to a memory stick.
- Ethernet (Modbus/TCP, SUTO-Bus) interface for transferring the data to SCADA systems.
- Data logger: 100 million values.
- Integrated report generator for compressed air audits (generates PDF files and copies them to a USB memory stick).
- All in one portable hand carried measurement device.
- TÜV approved measurement technology and quality assurance.
- Multi dew point measurement system for a big range of measurement beside a very high accuracy.
- Latest PID sensor technology for oil vapor measurement.
- Five values in a single device: Particle counter, dew point/humidity, oil vapor, temperature and pressure (flow measurement as option).
- Isokinetic sampling tube for particle measurement as option.



## 4. Technical Data

### 4.1 General

<b>CE</b>			
Data logger	Internal, 100 million values		
Parameter	Measuring parameter	Range	Reference
	Particle	0,3... 0,5 µm 0,5... 1,0 µm 1,0... 5,0 µm	Annex 1 / DIN 14644 (with isokinetic sampling device DIN 8573)
	Dew point	-100°... +20°C	DIN 8573
	Oil vapor	0,003... 10 mg/m <sup>3</sup>	ZLG/ AIM 07120604
	Pressure	0...15 barg	DIN 1301
	Temperature	0... 50°C	DIN 60751
Reference settings	ISO 1217, 20°C 1000 mbar DIN 1343, 0°C 1013 mbar		
Measurement principle	Parameter	Principle	
	Particle quantity	Laser optical detection	
	Dew point	Ceramic humidity sensor, oscillating crystal	
	Oil vapor	PID	
	Volume flow	Thermal mass flow (Anemometer)	
Medium	Compressed air, non corrosive components		
Humidity of the medium	< 40%, not condensing		
Temp. of the medium	0°C... 50°C		

Operation pressure	3... 15 barg
Housing material	PC + ABS, Aluminum
Protection class	IP 65 (cover closed)
Dimension	Please observe the drawings on the next page
Display	5" graphics color display, 800 x 4800 Pixel with touch screen interface
Weight	6,80 kg

## 4.2 Electrical data

Power supply	Mains supply adaptor (AC/DC) Input: 100... 240 VAC, 50/60 Hz, 1.4 A Output: 24 VDC, 2.5 A, 60 Watt max.
--------------	---

## 4.3 Accuracy

Accuracy	Parameter	Accuracy
	Particle quantity	50% @ 0,3... 0,4 $\mu\text{m}$ (per JIS) 100% @ 0,4... 5,0 $\mu\text{m}$ (per JIS)
Dew point	$\pm 2^\circ$	
Oil vapor	5% of value $\pm 0,003 \text{ mg/m}^3$	
Volume flow	$\pm 2 \%$ of value $\pm 0,3 \%$ of range	
Temperature	$\pm 0,1 \text{ K}$	
Pressure	$\pm 0,08 \text{ bar}$	

## 5. Dimensions

Dimensions S 600 in mm (cover closed):

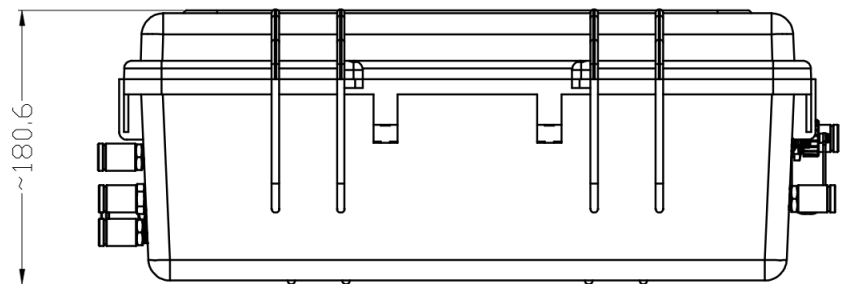
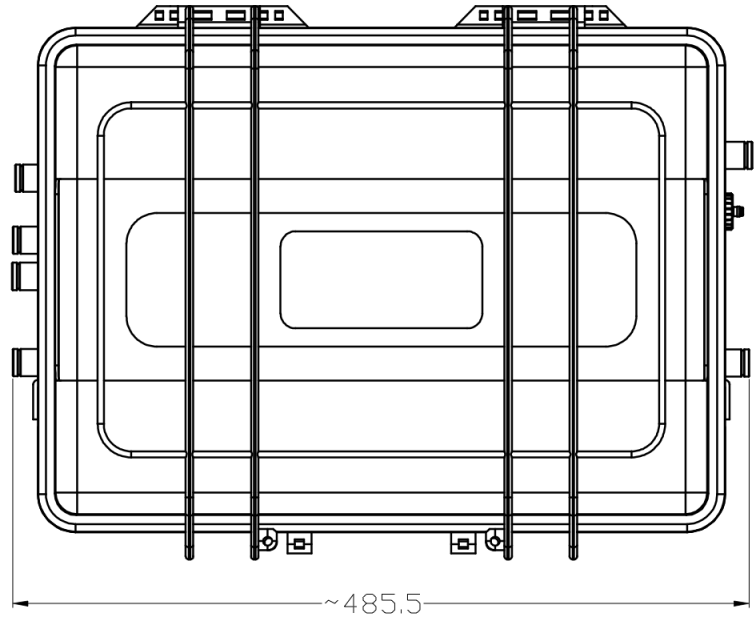
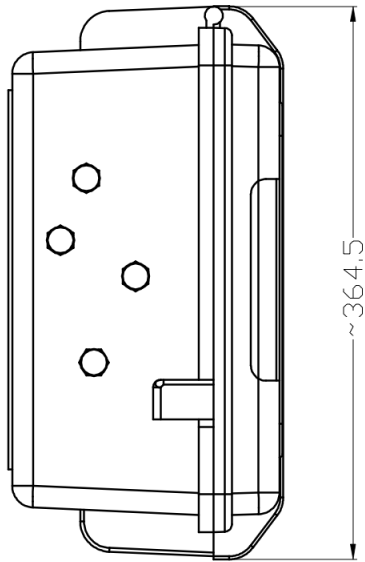

Dimensions isokinetic sampling device (option) in mm:

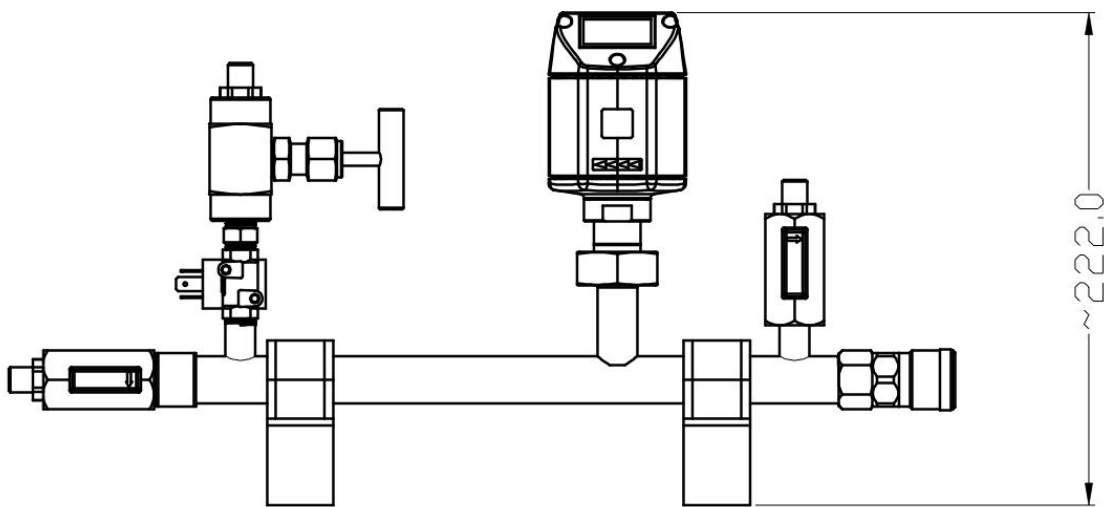
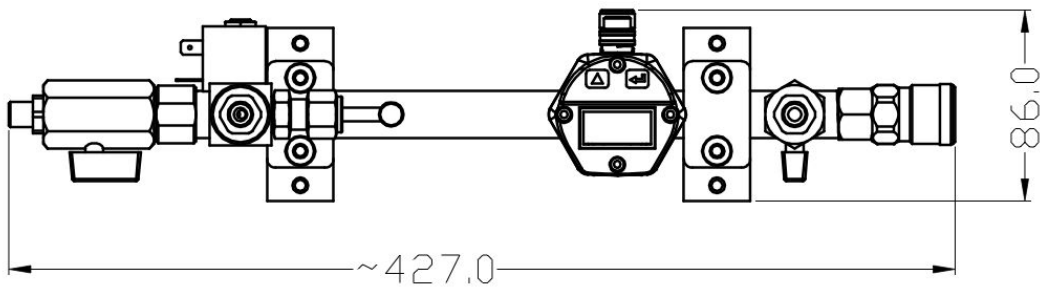

3D view of the S 600 and the isokinetic sampling device:

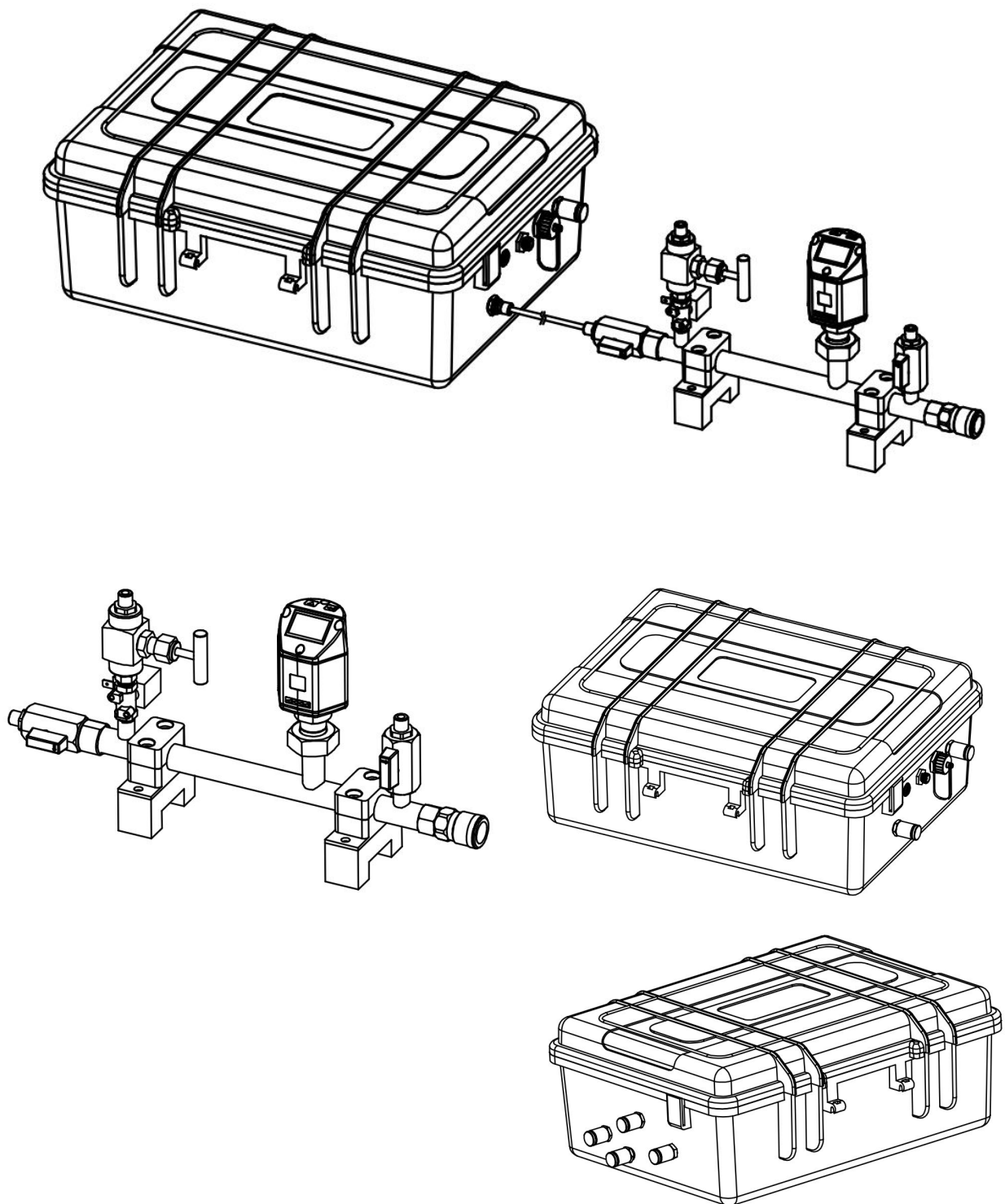

## 6. Installation on site

Please make sure that all components listed below are included in your package.

Qty.	Description	Item No.
1	S 600 portable compressed air analyzer in a hand carry case with handle and shoulder belt	0560 0600
1	USB OTG memory stick	0554 0087
1	Operation and instruction manual	PDF no P/N
1	Purge filter for pre-measurement (test kit)	0554 0604
5	6mm Teflon hose adapter, stainless steal	0219 0197
1	Power supply, 230 VAC / 24 VDC	0554 0086
1	2 m Teflon hose, 6 OD x 4 ID mm, free adjustable	0193 0002
1	1.5 m Teflon hose with quick connector	0554 0003

*The below items only apply if you have the isokinetic sampling device 0554 0600 as option*

1	Isokinetic sampling device, incl. flow sensor	0554 0600
1	M12 connection cable for isokinetic sampling device	0553 0134

If you need replacement materials from the list above or if you need further useful accessories please contact the manufacturer or your local distributor.

### 6.1 Installation requirements

The device needs to be set up next the measuring point. Please make sure that the device is standing on a flat surface. In case you are using the additional isokinetic sampling device you must make sure that they also stand on a flat surface next to the S 600.

The tubes should be not bended to strong and be installed with a big curve radius to avoid turbulences in the air flow.

The isokinetic sampling device must be set up next to the S 600 to get a straight and short connection. Please observe the following chapter, connecting the isokinetic sampling device to the S 600.

The S 600 must be connected to the power during the measurement, please make sure that the device is not turned off or plugged of during the measurement, since the data will then be lost and not saved.

**ATTENTION!**

**If the device is not installed properly it could lead to wrong measurement results.**

- The device is designed to be operated indoors only. If you want to use the device outdoors, direct sunlight and rain must be avoided.

**ATTENTION!**

**Before you connect the device to your point of measurement, you have to make sure that there is no rough contamination like water/oil drops or heavy dust. This could damage the sensor units.**

**For this please use the purge filter test kit.**

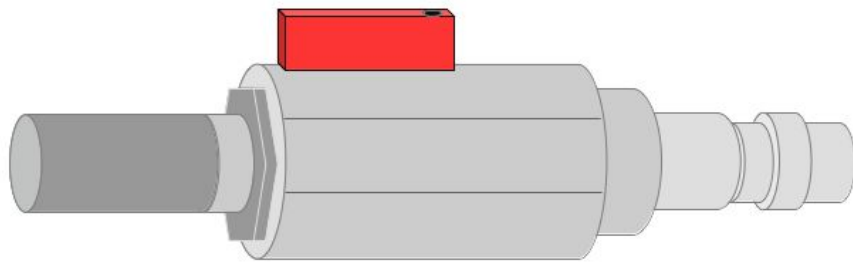

To check your point of measurement connect the purge filter test it onto your measuring point first. Open the purge valve on the test kit and purge some air for a short period. Afterwards check the filter in the test kit, if it shows high contamination of water, oil or dust. Should the filter be contaminated to high do not continue to measure with the S 600 as this may lead to serious damage. In case you are not sure, please contact the manufacturer.



**ATTENTION!**  
**Before connecting the compressed air, make sure that all protection caps are opened/removed!**

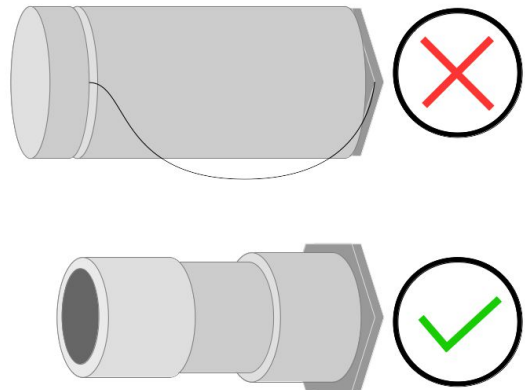

Remove the protection caps from all parts of both sides of the instrument. If not removed the device may get damaged and its the risk of bursting parts under high pressure, this can lead to a damage or to personal injuries. All exhaust outlets will pass air during the measurement, if not, please contact the manufacturer.



**ATTENTION!**  
**Always use the 6 mm Teflon hose adapter to connect the teflon hoses to the S 600 and to the isokinetic sampling device! You may damage the device if not used.**

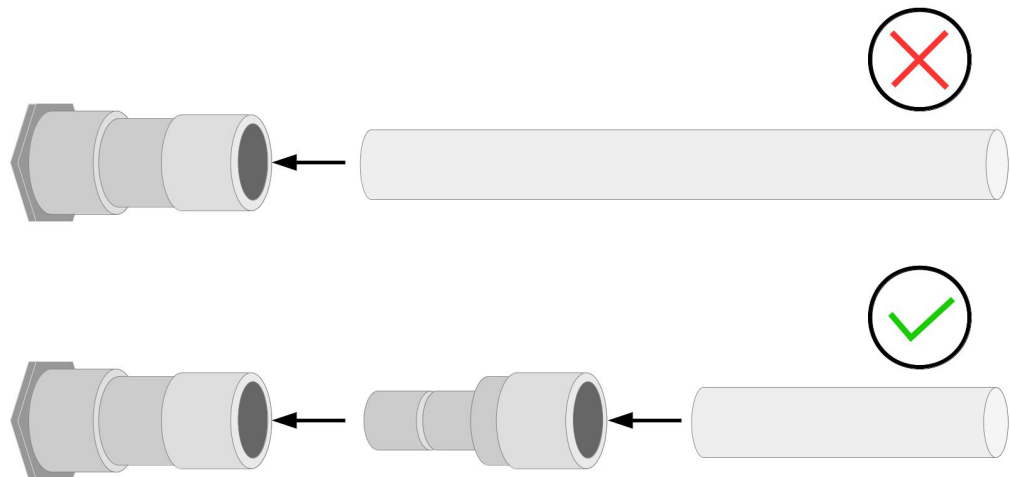

Using a quick connector more than once may lead to particle contamination which can affect the measurement. For this please use the included adapter plugs and keep them on your tubes.



## 6.2 Connecting the isokinetic sampling device to the S 600 analyzer (Option)



The picture above shows the setup together with the isokinetic sampling device connected to the S 600. Please connect the isokinetic sampling device using the teflon hose which came with the device. On the next page you will find a detailed description of the sampling device. Also you will find which outlets of the sampling device need to be connected to which input at the S 600.

Below you find it as a graphic for better understanding.

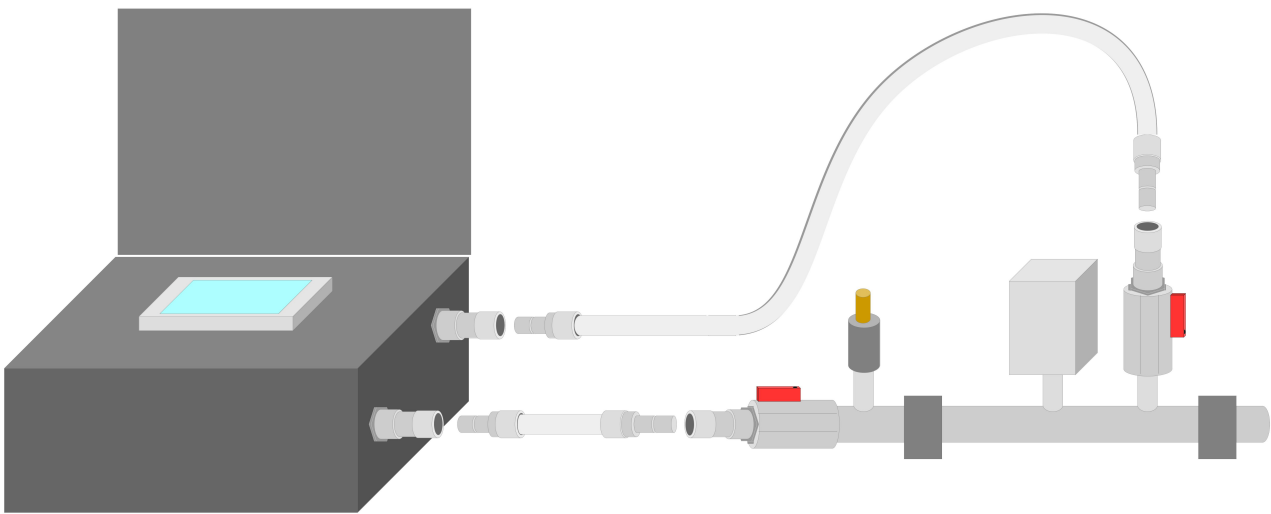

Before connecting you compressed air, make sure ball valve **2 and 4 are closed** properly.

**Close the needle valve 3** properly.

The connection to you compressed air system is achieved through the correct fitting (quick connector, teflon hose, etc.). **Connect your compressed air** system using the correct fitting to the **inlet 1**.

Connect the outlet valve **2** to the inlet for **dew point and oil vapor** measurement at the S 600 using a teflon hose.

Connect the isokinetic outlet **4** with the inlet for the **particle counting** at the S 600.

Now open outlet valve **2** and **4** to start your measurement. Follow the instructions on the screen.

### 6.3 Using the S 600 without the isokinetic sampling device

Connect your compressed air system using two teflon hoses to the corresponding inlets at the S 600. They are marked: *Gas inlet Oil / Dew point measurement* and *Gas inlet Particle measurement*.

### 6.4 Electrical connections on the S 600

The S 600 offers three types of electrical connections. The **power supply connector 1**, the **communication port for the isokinetic sampling device 2** and a **ethernet port 3** to communicate with network devices.

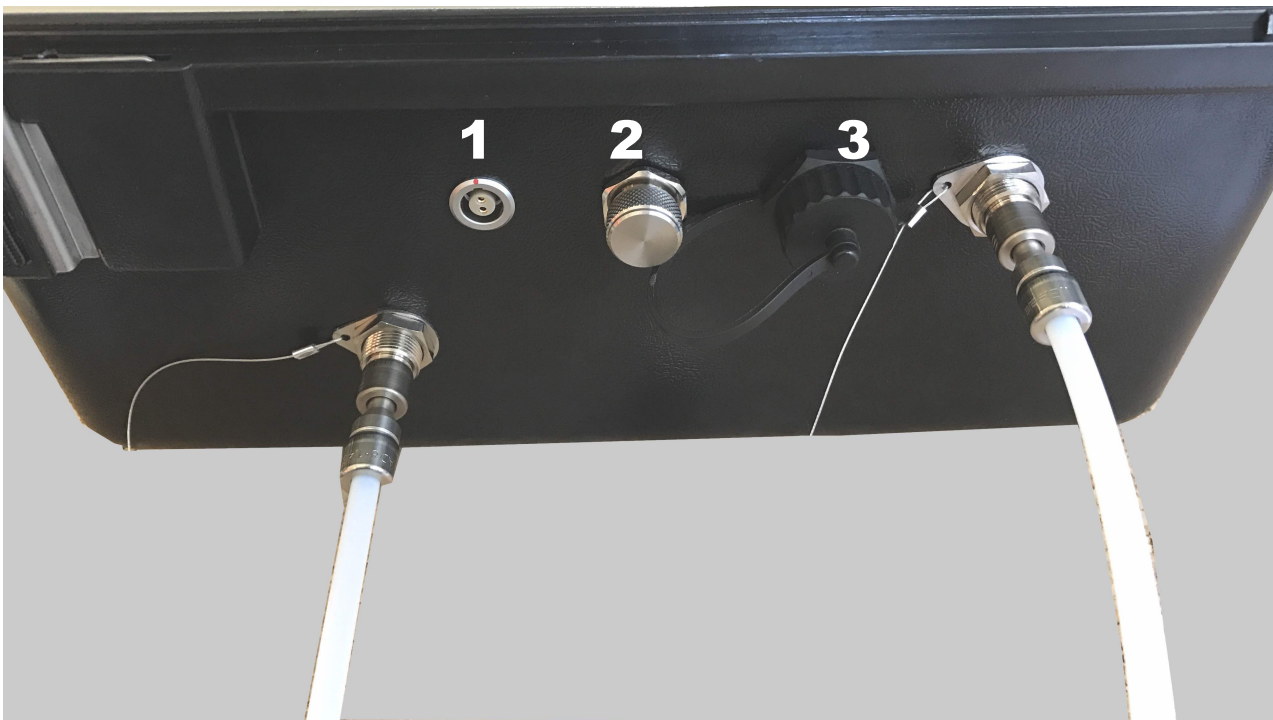

#### ATTENTION!

**Only use the power supply which came with the S 600!**

## 6.5 Compressed air connections (In and outlet)



The S 600 offers two compressed air inputs on the right side of the housing. The inlets are shown on the picture above and are marked respectively to their functions: *Gas inlet Oil / Dew point measurement* and *Gas inlet Particle measurement*.



### **ATTENTION!**

#### **Permissible pressure!**

**Please observe the maximum permissible ingoing pressure. It must be in between 3 and 15 bar overpressure. If the pressure is exceeded it will damage the device, if the pressure is to low, the volume flow will not be high enough which will lead to wrong results.**

In the picture below the left side of the housing is shown where the gas outlets can be found. The calibration outlets *Gas outlet Dew point measurement* and *Gas outlet Oil vapor measurement*, which are used to connect the internal sensors to references. These calibration outlets must be opened all the time during compressed air is connected. Also the two other ports need to be opened before connecting the compressed air.

**Note!**

**All gas outlets of the measurement device must stay opened during the complete usage of the device.**

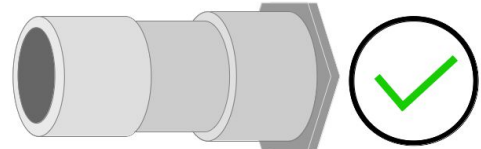
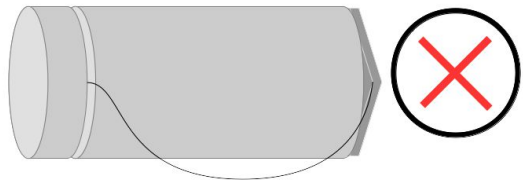

Then there are four more outlets on the left hand side of the device. These two outlets need to be opened during the measurement.



## 7. Setup and configuration

The S 600 is configured ex work and ready to measure as you receive it. There are no additional setups which must be done by the user. The setup of the single measurement rows are done during the measurement, as the user is guided through the single steps.

The setups are saved into the device and will be kept even after a power off.

There can be done some general configurations, for this please refer to the chapter 8.8.



**Note!**

**If you are facing problems setting up you device, please feel free to contact the manufacturer or your local dealer for assistance.**

## 8. Operation



When the S 600 gets powered you will see the start up screen. The progress bar shows, that the sensors are configured and the device is running some initialization routines.

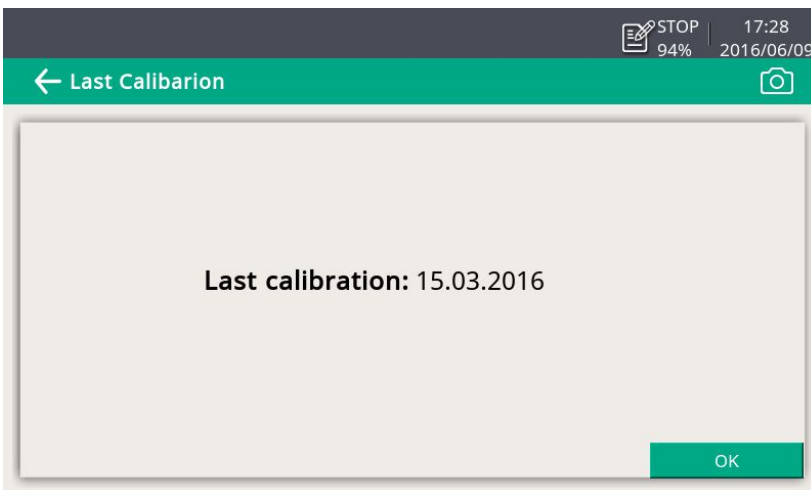

After the initialization the date of the last calibration is shown.

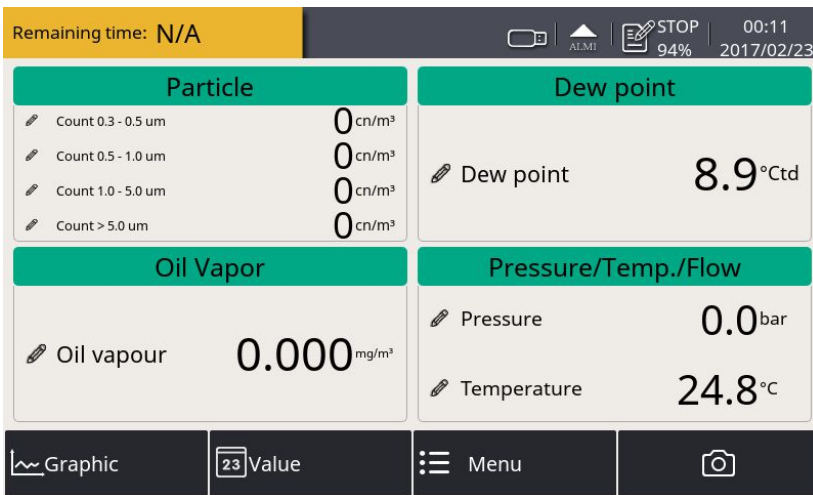

After the confirmation of the calibration date the main screen (Value) will be shown. From there you have access to the graphics view, the menu. By pressing the camera symbol, you are able to take screenshots.

### 8.1 Value screen

In this view, the S 600 shows all measured values in realtime.

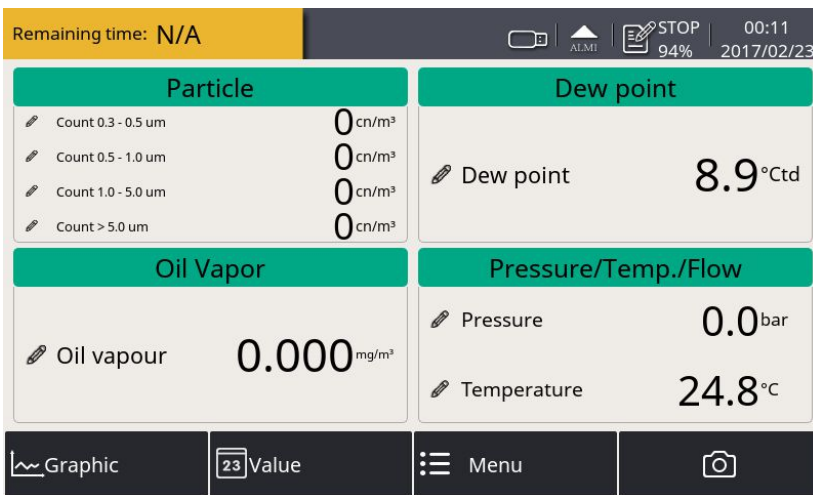

The user can switch to the value screen by pressing value in bottom bar. It will show the measured values in realtime.

## 8.2 The menu

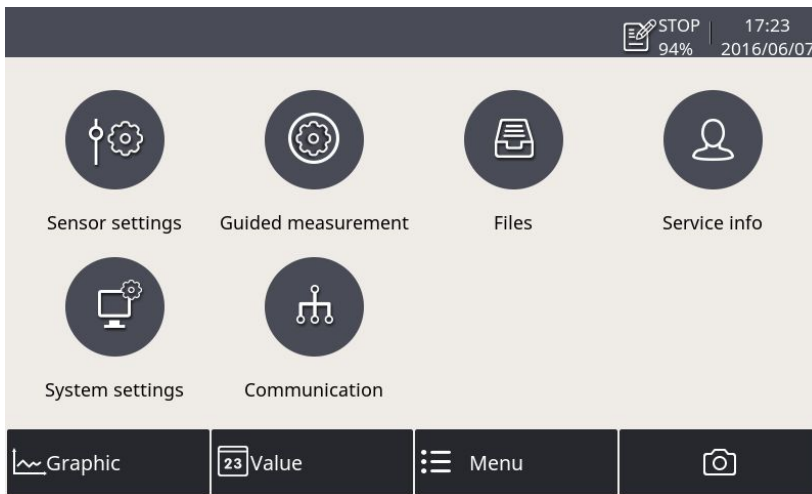

The user can get to the main menu by pressing the menu bar in the bottom bar. From here the user can get to different sub-menus like the guided measurement or the system settings.

The main menu offers the access to the following sub-menus.

### **Guided Measurement**

Within this menu the user can start the guided measurements, which will lead through a complete measurement cycle.

### **Files**

The user can access the saved screenshots, at the same time the memory usage can be accessed.

### **Service info**

This menu shows contact informations in case the user needs support.

### **System settings**

In the system settings general settings like date, time and language can be done. Furthermore the system settings will provide informations like the serial number.

**Communication** Field bus settings and communication parameters

## 8.3 Symbol description in the status bar

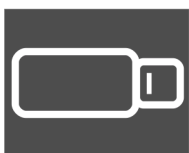

USB memory stick is connected. By pressing the icon the stick can be ejected.



System error, press the button to get further informations.



Calibration is overdue, please contact the manufacturer of your local dealer.

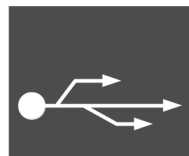

The S 600 is connected to a PC by USB cable.





**Data logger**  
**STOP:** The data logger is currently not running.  
**LOG:** The data logger is currently recording data.

### 8.4 Graphic view

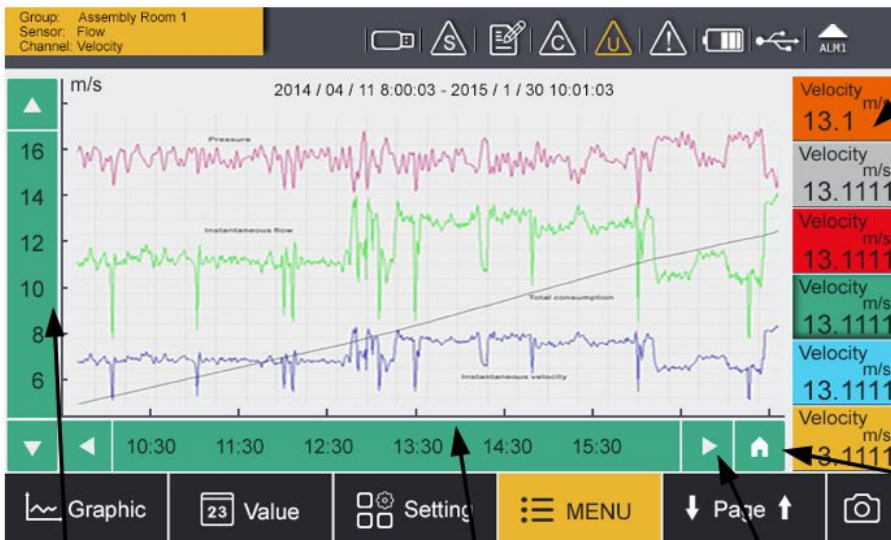

Selected channels and Y-axes:

- 1 touch select Y-axes
- Next touch disables channel
- Long touch is for settings

Home button: brings you back to the current time

Touch Y-axes to scale it

Touch X-axes to define viewing period

Time scrolling

The graphical view is preset ex works, so the user does not need to change anything. In case something needs to be changed, it can be easily done by following the instructions above.

### 8.6 Files

The files menu shows the user the screenshots. The screenshots can be shown, exported and deleted. At the same time the memory status can be checked.

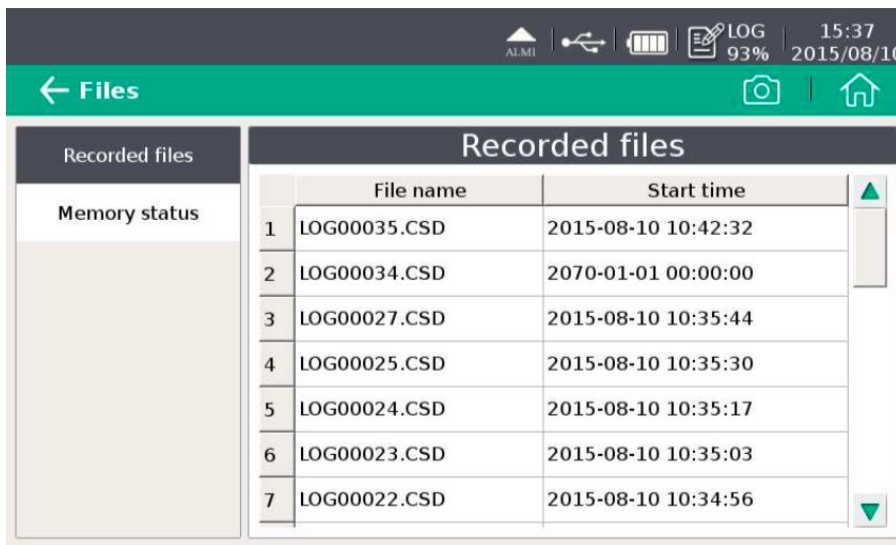

### 8.7 Service Info

Shows contact informations in case support is needed.

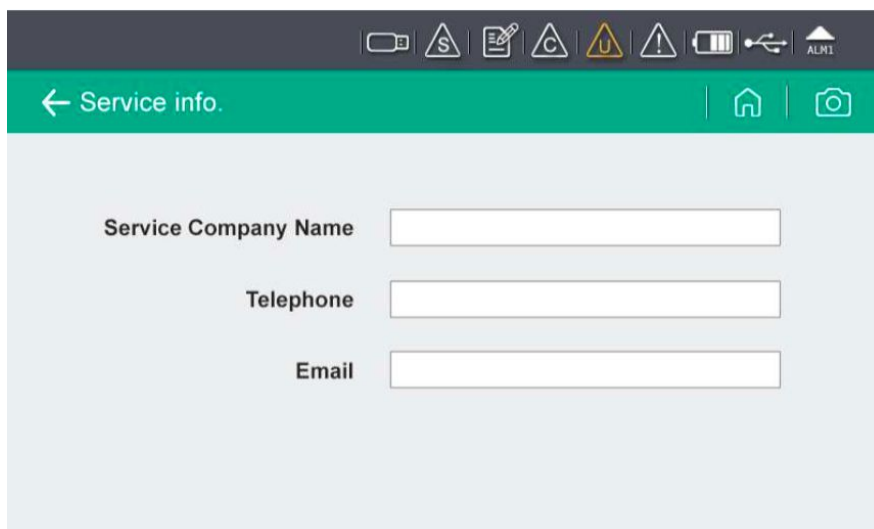

### 8.8 System Setting

General settings can be done in this menu. For this click the corresponding buttons.

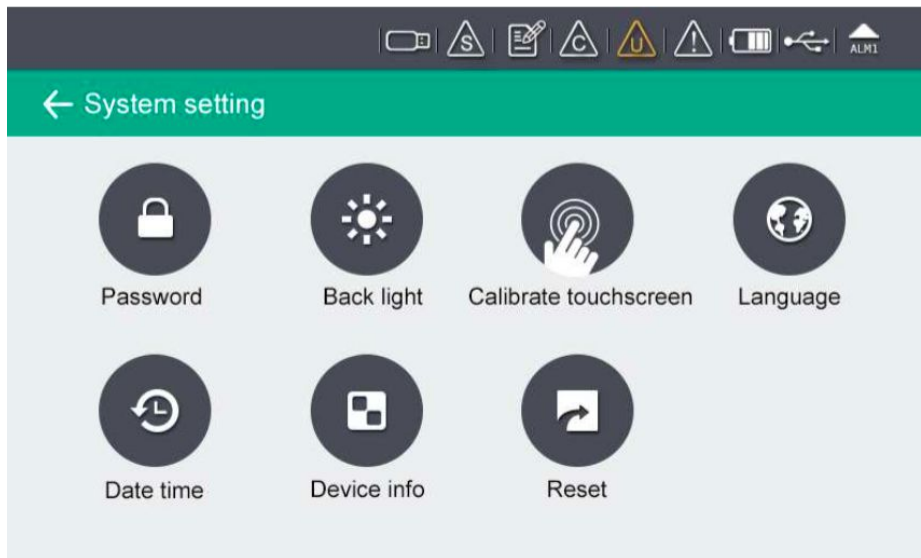
**Password**

A passphrase can be set to protect the settings menu from unwanted access.

**Back light**

Set up the brightness and the auto dimming function of the screen.

**Calibrate touch screen**

If the touch screen does not respond to user inputs correctly or not precisely, it can be calibrated.

**Language**

Set the interface language.

**Date time**

Date and time settings.

**Device info**

Device informations like serial number.

**Reset**

Restart the device (User settings will be saved).

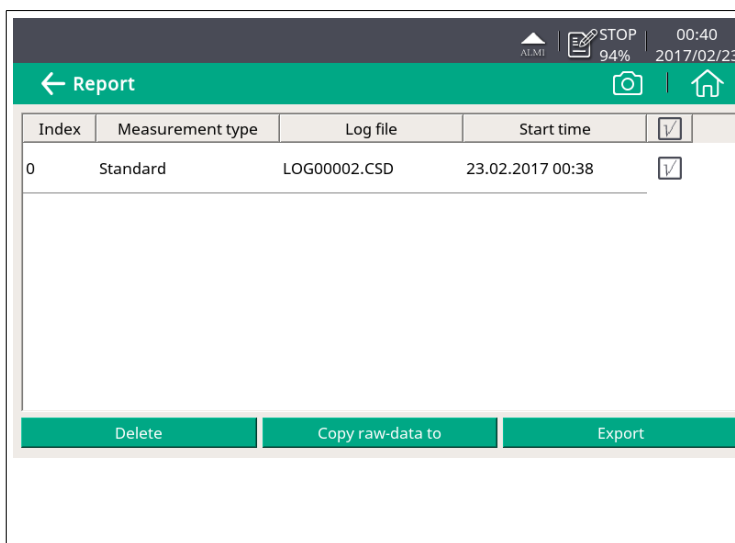
**8.9 Report menu**

Index	Measurement type	Log file	Start time	<input type="checkbox"/>
0	Standard	LOG00002.CSD	23.02.2017 00:38	<input checked="" type="checkbox"/>

In the report menu you can show the measurement results, just click on the file (not the box on the right). This will open a pop up window to show the PDF preview.

If you mark the file on the right side box, you will see the bottom menu and you can copy the PDF report or the raw data to a connected USB OTG stick.

## 9. Guided measurement

The S 600 provides a software based guided measurement which will lead the user through the complete measurement. This leads to a simplified measurement process and prevents the user from wrong measurements. The guided measurement is started by clicking the menu button guided measurement.

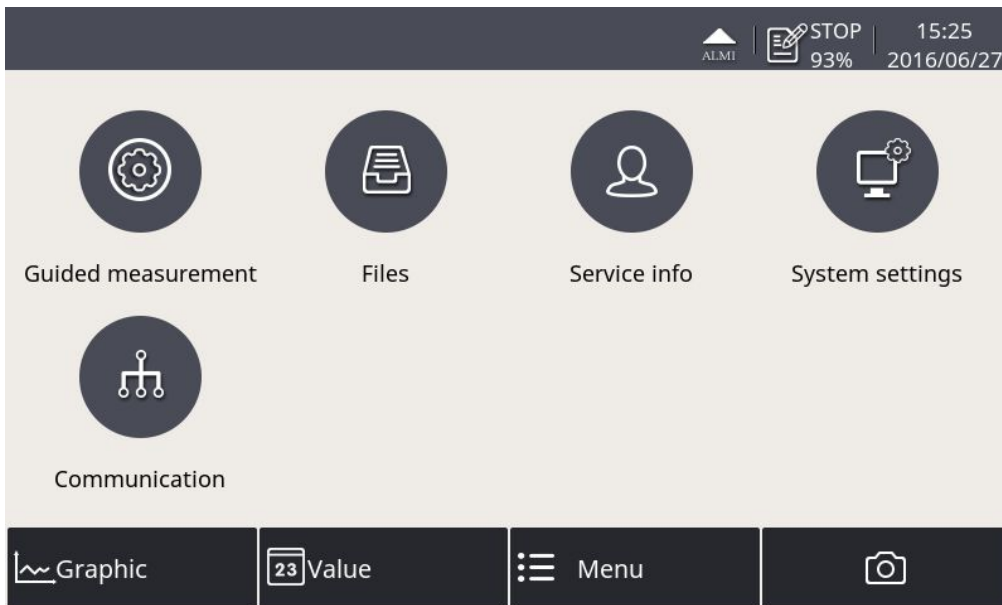

In the next step the user can decide which type of measurement should be performed.

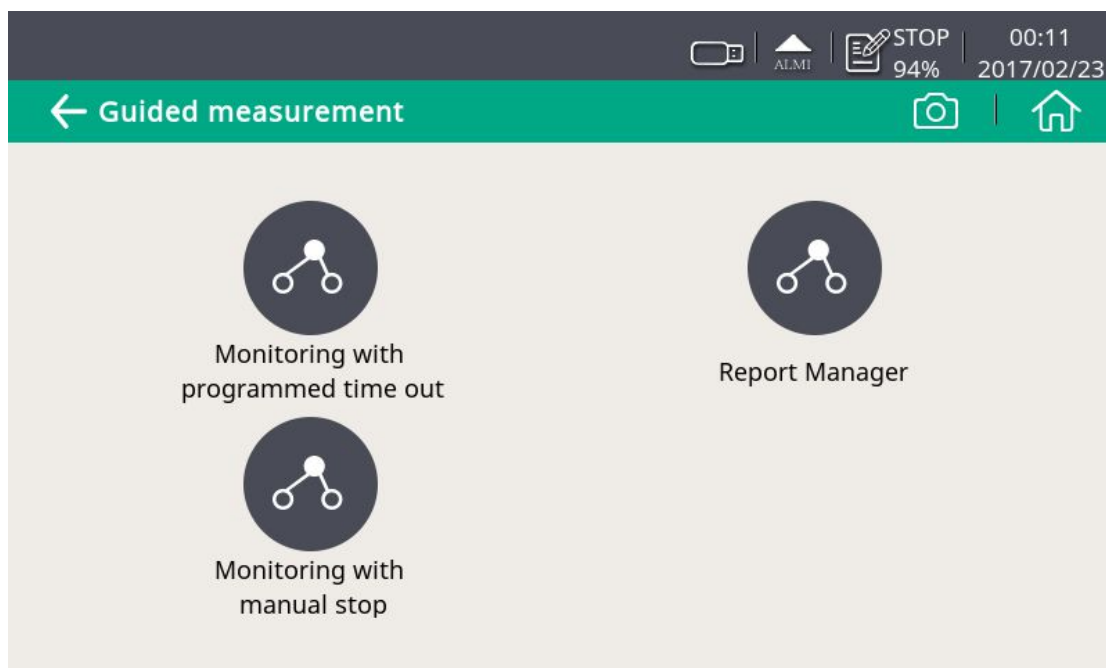

## Monitoring with programmed time out

This will start a measurement with a user-programmed period of measurement time. You can set the measurement time during the process of measurement preparation. The system will then, after finishing the programmed measurement duration, stop the measurement automatically and save the data. This mode is ideally used for audits where you have to measure at several points. You can program for each point a duration of e.g. 2 hours and you are then able to compare the measurements.

## Monitoring with manual stop

This will start the measurement without a programmed stop time. You can use this to start the measurement and when you come back you can stop it. Then you can decide if you want to keep the data or if you want to delete the data. This can be used to monitor values and to see if there are any changes.

### 9.1 Guided measurement

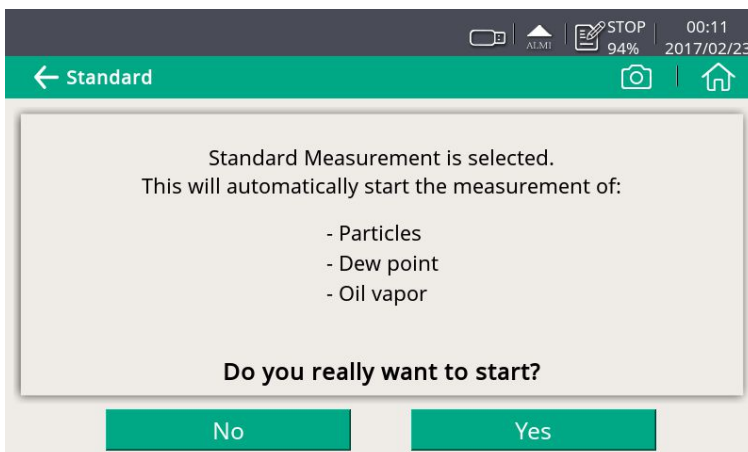

A overview will be given about the selected measurement type.

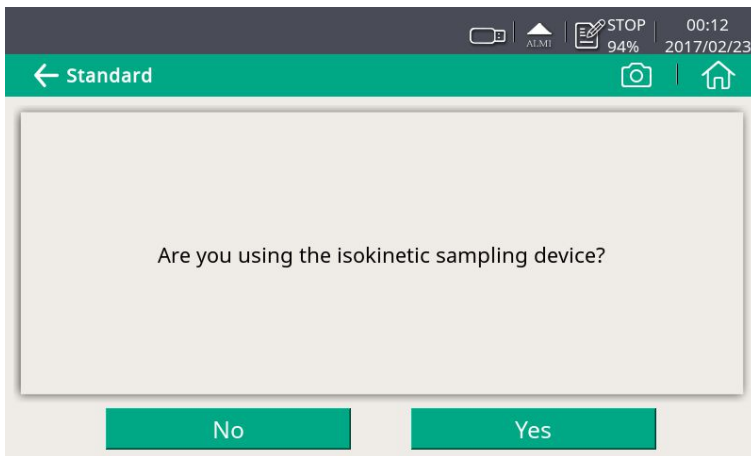

The system will ask if you are using the isokinetic sampling device, this will affect the further steps and instructions. Select yes if you have the isokinetic sampling device connected.

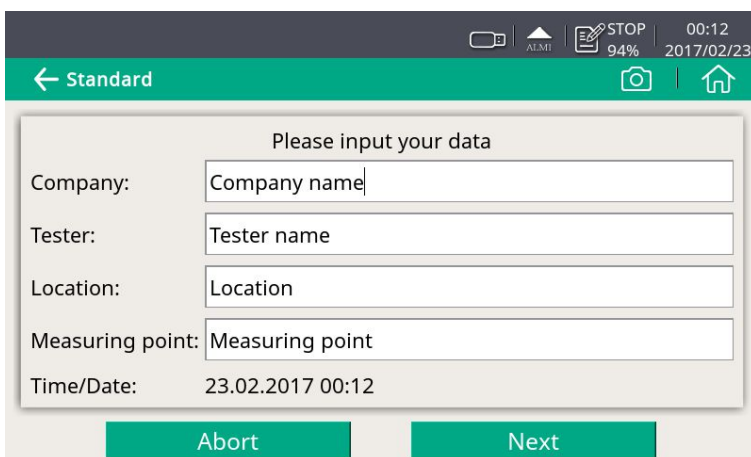

Please input your user data, this will be then shown on the report.

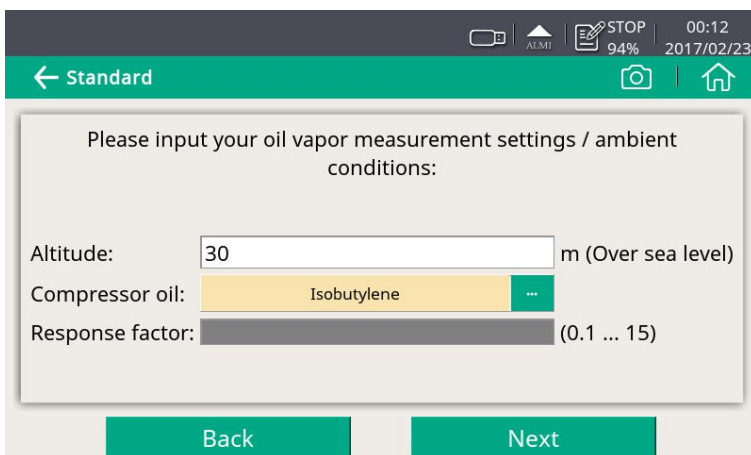

The ambient conditions like the sea level are needed to be defined. Also the oil type can be selected (Isobutylene is recommended as this will meet the most oil characteristics).

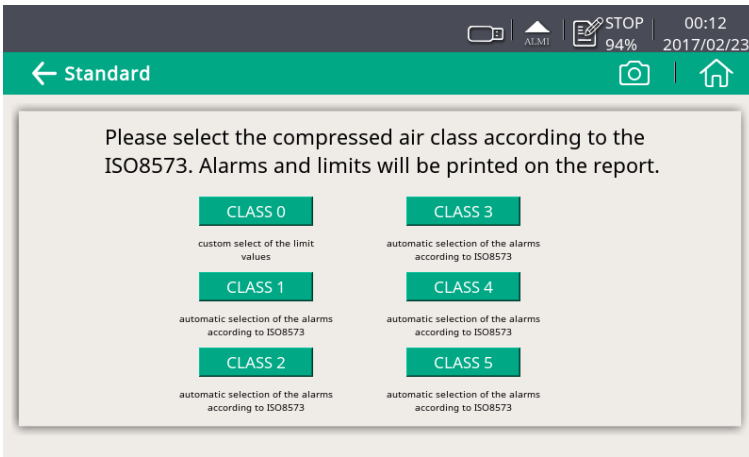

Select now your compressed air class, which will then select the corresponding alarms.

Select CLASS 0 to get to custom alarm setting, where you can set the custom alarms to your needs.

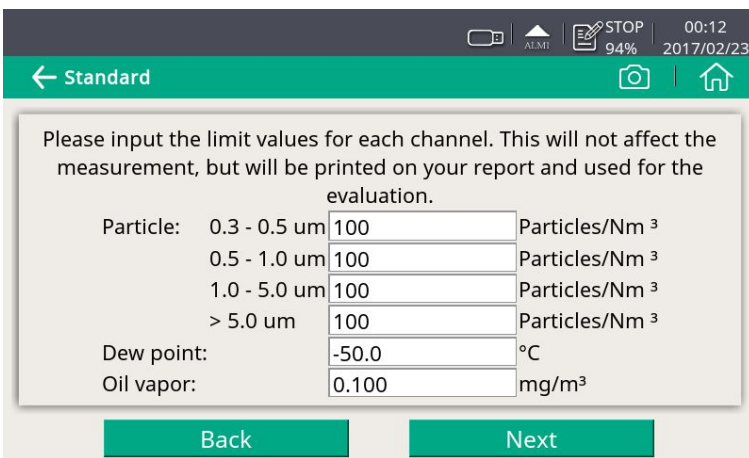

The user has to define the limits values for each measurement channel when selected CLASS 0. By this the user is able to select different alarm settings as needed by the quality management.

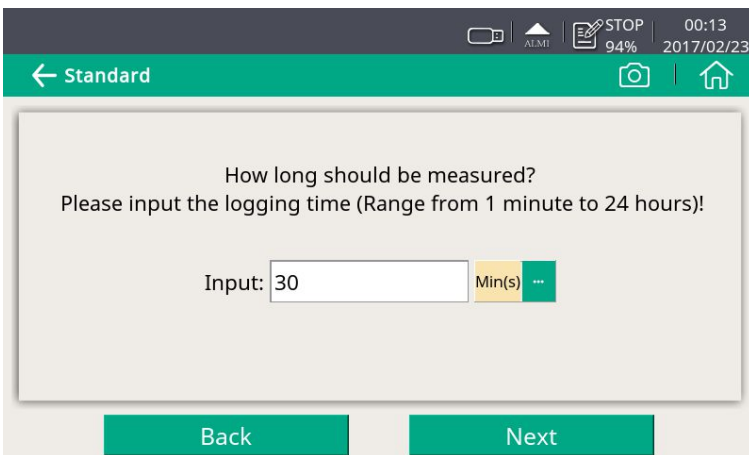

It has to be defined how long the measurement should take. The longer it takes, the more the values are stabilized and represent the system conditions exactly.

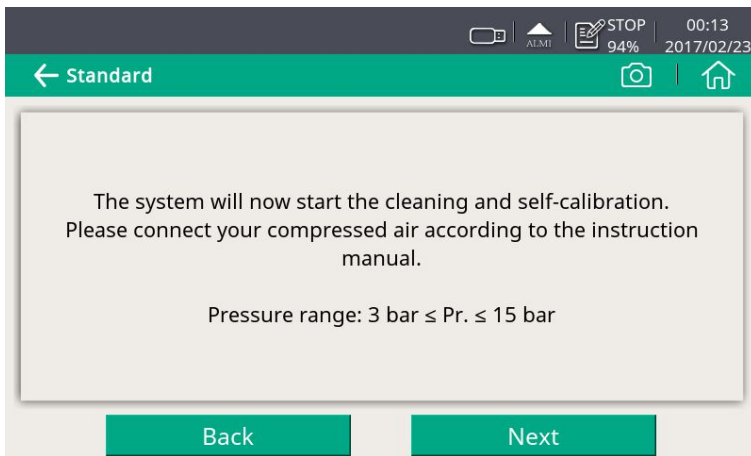

The system will check if the pressure is in valid range.

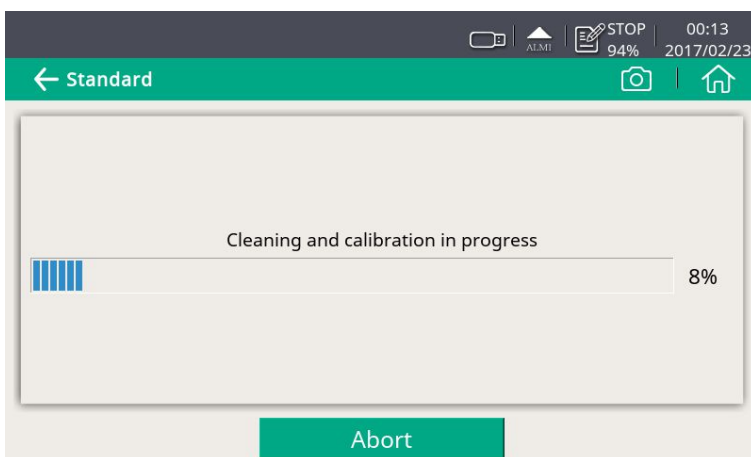

The system is performing the self calibration cycles and is cleaning the internal sensor elements.

**The following 3 steps only apply if you selected yes for the isokinetic sampling device, otherwise skip the next 3 steps**

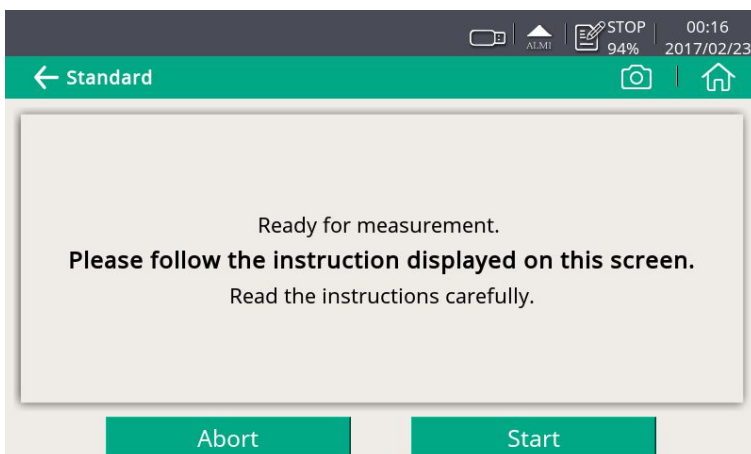

The S 600 is now ready for measurement. Please read the instructions shown on the screen carefully.



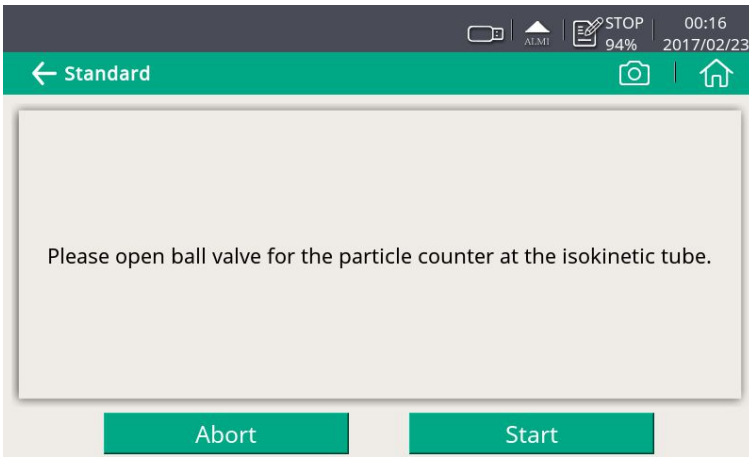

Follow on screen instructions.

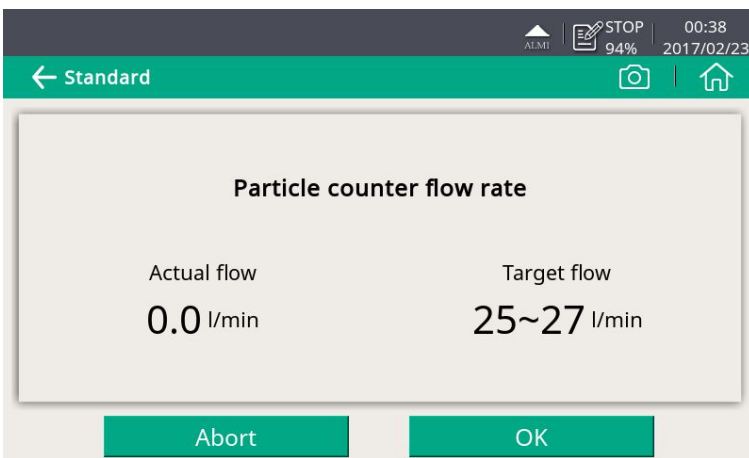

Set up the flow rate shown on the screen.

**The device is ready and will start to measure. The remaining time will be shown on the top left corner.**

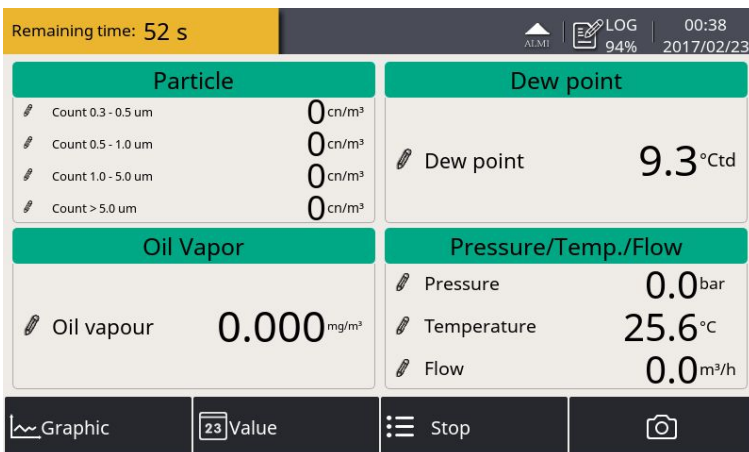

Measurement has started. Logging is indicated by the pens moving on the screen. Also the status bar icon switches from STOP to LOG. The remaining time is displayed in the upper left corner. Please wait. The system will stop the measurement automatically.

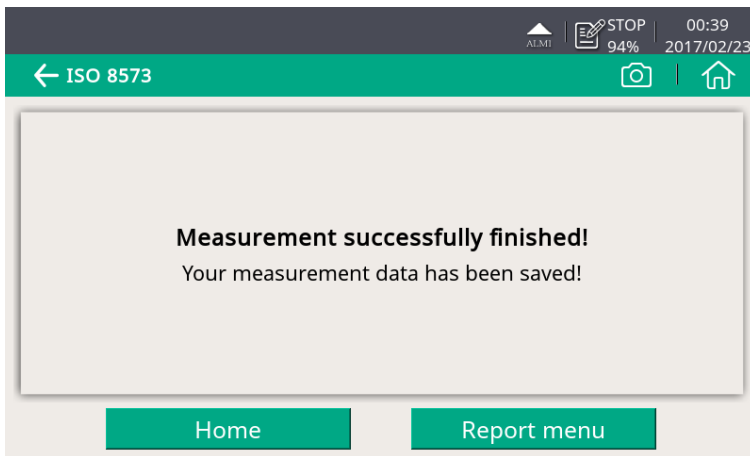

The measurement finished successfully.

## 10. Optional accessories

Is it possible to get the following accessories as options. For this please ask the manufacturer or your local dealer.

- Isokinetic sampling device, for particle sampling according to ISO 8573.
- Teflon hoses and sorts of adapters.

## 11. Maintenance

Use a moist fabric to clean the device. For the use in GMP-area it is possible to disinfect through wipe disinfection. For this please contact the manufacturer or your local dealer.



### **ATTENTION!**

**Please dry the device after cleaning using a clean and dry fabric. Always take care, that the fabric for cleaning is not to wet as water could get into the device and lead to damage.**

## 12. Disposal or waste

Electronic devices are recyclable material and do not belong in the household waste.

The sensor, the accessories and its packings must be disposed according to your local statutory requirements. The dispose can also be carried by the manufacturer of the product, for this please contact the manufacturer.

## 13. Warranty

SUTO iTEC GmbH provides a warranty for this product of 24 months covering the material and workmanship under the stated operating conditions from the date of delivery. Please report any findings immediately and within the warranty time. If faults occurring during the warranty time SUTO iTEC GmbH will repair or replace the defective unit, without charge for labour and material costs but there is a charge for other service such as transport and packing costs.

Excluded from this warranty is:

- Damage caused by:
  - Improper use and non-adherence to the instruction manual.
  - Use of unsuitable accessories.
  - External influences (e.g. damage caused by vibration, damage during transportation, excess heat or moisture).

The warranty is cancelled:

- If the user opens the measurement instrument without a direct request written in this instruction manual.
- If repairs or modifications are undertaken by third parties or unauthorized persons.
- If the serial number has been changed, damaged or removed.
- If the warranty sealing is removed or damaged.

Other claims, especially those for damage occurring outside the instrument are not included unless responsibility is legally binding.

Warranty repairs do not extend the period of warranty.



### **ATTENTION!**

**Batteries have a reduced warranty time of 12 month.**

---

## SUTO iTEC GmbH

Werkstr. 2  
79426 Buggingen  
Germany

Tel: +49 (0) 7631 936889-0  
Fax: +49 (0) 7631 936889-19  
Email: [sales@SUTO-itec.com](mailto:sales@SUTO-itec.com)  
Website: <http://www.SUTO-itec.com>

## CS-iTEC Co., Ltd.

Room 10, 6/F, Block B, Cambridge Plaza  
188 San Wan Road, Sheung Shui, N.T.  
Hong Kong

Tel: +86 (0) 755 8619 3164  
Fax: +86 (0) 755 8619 3165  
Email: [sales@cs-itec.asia](mailto:sales@cs-itec.asia)  
Website: <http://www.cs-itec.com>