

Spot Drilling Collar

For the later setting of a measuring point



Safety instructions

Please check whether this manual corresponds with the instruments type.

Please observe all notes indicated in this instruction manual. It contains essential information which have to be observed during installation, operation and maintenance. Therefore this instruction manual has to be read categorically by the technician as well as by the responsible user / qualified personnel before installation, initiation and maintenance.

This instruction manual has to be available at the operation site of the spot drilling collar at any time.

Regional respectively national regulations have to be observed in addition to this instruction manual if necessary.

In case of any obscurities or questions with regards to this manual or to the collar please contact SUTO-iTEC GmbH.



Warning !

Compressed air !

Contact with quickly or abruptly escaping compressed air or bursting parts of the system may cause severe injuries or death.

Measures:

- Do not exceed the maximum operation pressure (see type label)!
- Only use pressure-tight installation material!
- Avoid persons or objects being hit by escaping compressed air!



Warning !

Inadmissible operating parameters!

Undercutting or exceeding of limit values may cause danger to persons and material and may lead to functional and operational disturbances.

Measures:

- Do not exceed the maximum operation pressure (see type label)!
- Make sure that the spot drilling collar is only operated within the admissible limit values indicated on the type label.
- Careful observation of the performance data of the collar in connection with the application.

Further safety instructions:

- Also the applicable national regulations and safety instructions have to be observed during installation and operation.



Attention !

Leakages at the connection pipe / collar

Due to faulty installation there might be an escape of compressed air at the connection pipe / collar.

Field of application

The spot drilling collar with ball valve is designed for the later setting up of a measuring site at pressurized compressed air pipes are made from steel.

Please see chapter 7 "Drilling by means of the SUTO-iTEC drilling jig"

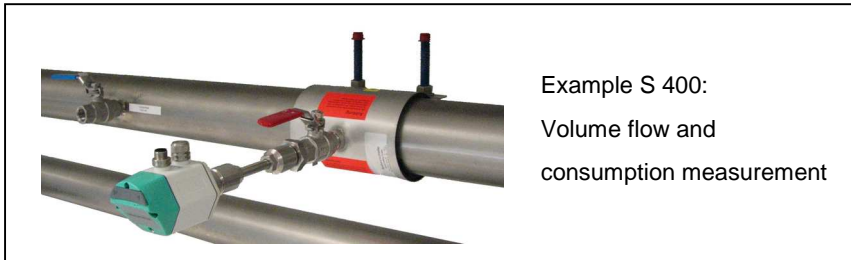

Single components of the spot drilling collar

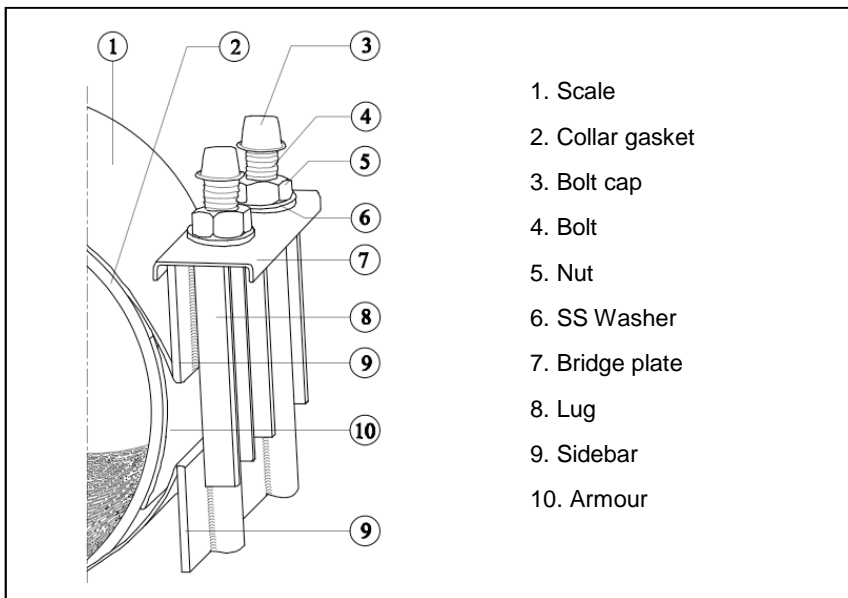

Before installation

- Check the diameter of the pipe and make sure you are using correctly sized collars.
- Clean the pipe to remove as much dirt and corrosion as possible from the surface. Scrape the pipe to remove dirt and corrosion so that the surface is smooth.
- Make sure no foreign material sticks to the gasket as it is wrapped around the pipe, nor becomes lodged between gasket and pipe as the nuts are tightened.
- Keep threads free of foreign material to facilitate tightening.
- Use a torque wrench to achieve proper torque. Also make sure you use the right wrench size (step 6).
- Bolts are often not sufficiently tightened if a torque wrench is not used. Take extra care in this situation to ensure proper tightening.

Montageschritte

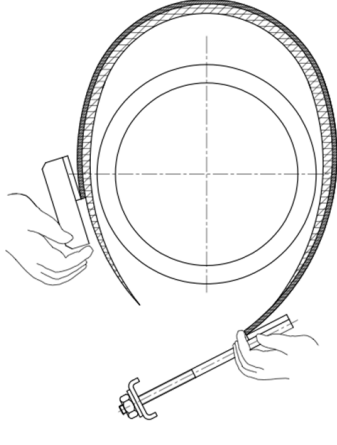
	<p>Step 1</p> <p>Mark the pipe where the ends of the collar will be. After installation use this mark to confirm that the collar has been properly positioned.</p>
	<p>Step 2</p> <p>Thoroughly clean the pipe surface area to be covered by the collar.</p> <p>Apply lubricant to pipe and rubber inside the collar to ensure a proper seal.</p> <p>DO NOT use grease!</p>
	<p>Step 3</p> <p>Back off nuts to end of bolts, but DO NOT REMOVE THEM. Open up the collar and wrap it around the pipe. (Fig. 1).</p>

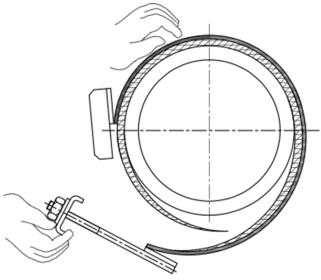
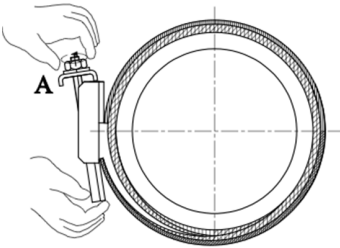
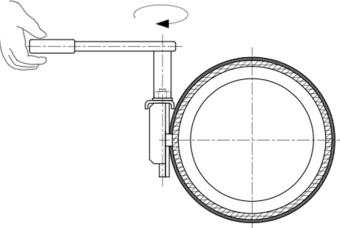
	<p>Step 4</p> <p>Position it in such a way that the bolts are conveniently placed for assembly and tightening (Fig. 2).</p>
	<p>Step 5</p> <p>Snap the bridge plate ONTO the lugs (Fig. 3). Do not use force. Be sure that the armour slides under the scale and that the gasket tails are not folded under, but are lying flat around the pipe. Tighten the nuts by hand first.</p>
	<p>Step 6</p> <p>Then use a torque wrench with a handle of at least 300 mm in length (Fig. 4) to tighten all nuts evenly in 20 Nm increments. This exerts pressure on the bolts and the bridge plate will slowly move towards the pipe automatically. Then you can easily knock the bridge plate into place over the sidebar edge.</p> <p>Recommended torque:</p> <p>M12: 65 Nm/ 19 mm Wrench size M14: 85 Nm/ 22 mm Wrench size M16: 110 Nm/ 24 mm Wrench size</p>
	<p>Step 7</p> <p>Wait 20 minutes and then retighten to proper torque.</p> <p>Backfill and compact carefully around collar.</p>
<p>Always pressure test for leaks before backfilling the ditch.</p> <p>If leakage occurs repeat step 3 - 7. Then pressure test again.</p>	

Drilling by means of the SUTO-iTEC drilling

jig Please observe the instruction manual for the drilling

- Do not exceed the max. pressure of 10 bar
- jig** • The drilling in the compressed air line should be carried out only by qualified staff
- Observe safety regulations for works at compressed lines
- The spot drilling collar has to be installed pressure-tightly
- Check the connection collar/pipe categorically before drilling. We recommend a pressure test. For this purpose please open the ball valve and charge it with the line pressure.
- A leakage check can be carried out quickly and easily by means of the SUTO-iTEC leak detector S 530.
- Use a slowly running drilling machine with the corresponding safety equipment.



Technical Data

Collars are usable for	Steel pipes with diameters from DN 25 to DN 200 (available diameters please see table on page 8)
Max. operation pressure	10 bar
Max. temperature	-5 °C to 50°C
Ball valve	I/A, 1/2", DN15
Material ball valve	1,4408, PN40
Material collar	1.4301 (AISI 304)
Material rubber collar	NBR, EPDM on request

Oder Information

Spot Drilling Collar incl. ball valve $\frac{1}{2}$"³, I/O	
For pipe outer diameters from – to	Order No.
026 - 030 mm, length: 100 mm	0530 1109
032 - 036 mm, length: 100 mm	0530 1109
036 - 040 mm, length: 100 mm	0530 1109
040 - 044 mm, length: 150 mm	0530 1109
044 - 051 mm, length: 200 mm	0530 1109
048 - 055 mm, length: 200 mm	0530 1109
052 - 059 mm, length: 200 mm	0530 1109
057 - 064 mm, length: 200 mm	0530 1109
063 - 070 mm, length: 200 mm	0530 1109
070 - 077 mm, length: 200 mm	0530 1109
075 - 083 mm, length: 200 mm	0530 1109
082 - 090 mm, length: 200 mm	0530 1109
087 - 097 mm, length: 200 mm	0530 1109
087 - 097 mm, length: 200 mm	0530 1109
102 - 112 mm, length: 200 mm	0530 1109
108 - 118 mm, length: 200 mm	0530 1109
118 - 128 mm, length: 200 mm	0530 1109
125 - 135 mm, length: 200 mm	0530 1109
133 - 144 mm, length: 200 mm	0530 1109
145 - 155 mm, length: 250 mm	0530 1109
151 - 161 mm, length: 250 mm	0530 1109
159 - 170 mm, length: 250 mm	0530 1109
168 - 180 mm, length: 250 mm	0530 1109
180 - 191 mm, length: 250 mm	0530 1109
193 - 203 mm, length: 300 mm	0530 1109
200 - 210 mm, length: 300 mm	0530 1109
209 - 220 mm, length: 300 mm	0530 1109
Other diameters on request	

Drilling jig

Drilling jig, drill Ø13 incl	0530 1108
------------------------------	-----------

Leak detector

Set S 530 leak detector	0601 0103
-------------------------	-----------