

Instruction and Operation Manual

S040

Atmospheric Sensor



Dear Customer,

Thank you for choosing our product.

The operating instructions must be read in full and carefully observed before you start up the device. The manufacturer cannot be held liable for any damage which occurs as a result of non-observance or non-compliance with this manual.

Should the device be tampered with in any manner other than a procedure which is described and specified in the manual, the warranty is canceled and the manufacturer is exempt from liability.

The device is destined exclusively for the described application.

SUTO offers no guarantee for the suitability for any other purpose. SUTO is also not liable for consequential damage resulting from the delivery, capability or use of this device.

Revision: 2025-2-1



Last modifications: December, 2025

Table of contents

1 Safety Instructions.....	4
2 Registered Trademarks.....	5
3 Application.....	6
4 Features.....	6
5 Technical Data.....	7
5.1 General Data	7
5.2 Operating Conditions.....	7
5.3 Electrical Data.....	7
5.4 Measurement.....	7
6 Dimensional Drawing.....	8
7 Installation	9
7.1 Electrical Connection.....	10
7.2 Wiring Diagram.....	10
8 Modbus Communication.....	11
8.1 Default Setting.....	11
8.2 Protocol Frame.....	11
8.2.1 Read-Holding Register	11
8.2.2 Write-Holding Register	12
8.2.3 Settings Save.....	12
8.3 Register.....	13
9 Calibration.....	15
10 Maintenance.....	15
11 Disposal of Waste.....	15

1 Safety Instructions

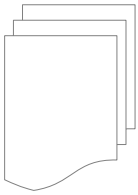

Please check if this instruction manual matches with the product type.

Please observe all notes and instructions indicated in this manual. It contains essential information to be observed before and during installation, operation and maintenance. Therefore this instruction manual has to be read carefully by the technician as well as by the responsible user / qualified personnel.

This instruction manual has to be available at the operation site of the Pressure Transmitter at any time. In case of any obscurities or questions, regarding this manual or the product, please contact the manufacturer.

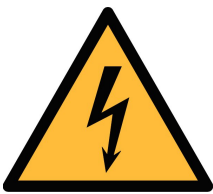

WARNING!

Voltage used for supply!

Any contact with energized parts of the product, may lead to an electrical shock which can lead to serious injuries or even death!

- Consider all regulations for electrical installations.
- The system must be disconnected from any power supply during maintenance work.
- Any electrical work on the system is only allowed by authorized qualified personal.



ATTENTION!

Permitted operating parameters!

Observe the permitted operating parameters, any operation exceeding this parameters can lead to malfunctions and may lead to damage on the instrument or the system.

- Do not exceed the permitted operating parameters.
- Make sure the product is operated in its permitted limitations.
- Do not exceed or undercut the permitted storage and operation temperature and pressure.
- The product should be maintained and calibrated frequently, at least annually.

General safety instructions

- It is not allowed to use the product in explosive areas.
- Please observe the national regulations before/during installation and operation.

Remarks

- It is not allowed to disassemble the product.
- Always use spanner to mount the product properly.



ATTENTION!

Measurement values can be affected by malfunction!

The product must be installed properly and frequently maintained. Otherwise, it may result in inaccurate measurement values.

- Do not exceed the maximum operation temperature at the sensors tip.

Storage and transportation

- Make sure that the transportation temperature of the sensor is between -40 ... +80°C.
- For transportation it is recommended to use the packaging which comes with the sensor.
- Please make sure that the storage temperature of the sensor is between -55 ... +80°C.
- Avoid direct UV and solar radiation during storage.

2 Registered Trademarks

SUTO®

Registered trademark of SUTO iTEC

MODBUS®

Registered trademark of the Modbus Organization, Hopkinton, USA

3 Application

The S040 Atmospheric Sensor is a high performance product that measures temperature, humidity, and pressure simultaneously.

It is designed for the monitoring of ambient air quality, as well as monitoring of clean rooms, production floors, and more.

The S040 cannot be used in explosive areas. For the use in explosive areas please contact the manufacturer.

4 Features

- Combination of atmospheric pressure, humidity, and temperature measurement in one sensor for ambient measurement
- High accuracy and reliability
- IP66 protection
- Stainless steel shell
- Modbus/RTU interface

5 Technical Data

5.1 General Data

CE	
Communication protocol	Modbus/RTU
Hardware interface	RS-485
Casing material	SS304
Protection class	IP66/67
Dimensions	See dimensional drawing on the next page
Electrical connection	M12, 4 pins
Approval	CE
Transport temperature	-55 ... 80°C
Weight	75 g

5.2 Operating Conditions

Ambient temperature	-40 ... +80°C
Ambient humidity	0 ... 100% RH
Storage temperature	-55 ... +80°C
Medium	Air, N ₂ , CO ₂
Operating pressure	Atmospheric pressure (0.3 ... 120 KPa)

5.3 Electrical Data

Power supply	5 ... 24 VDC, 25 mW
--------------	---------------------

5.4 Measurement

Temperature	
Measuring range	-40 ... 80°C
Accuracy	±0.5°C
Resolution	0.1°C
Response time T ₅₀	1 ... 5 s
Humidity	
Measuring range	0... 100% RH

Accuracy	$\pm 2.0\%$ RH
Resolution	0.1% RH
Response time T_{50}	1 ... 5 s
Atmospheric pressure	
Measuring range	0.3 ... 120 kPa
Accuracy	± 100 Pa
Resolution	1 Pa
Response time T_{50}	1... 5 s

6 Dimensional Drawing

Unit: mm

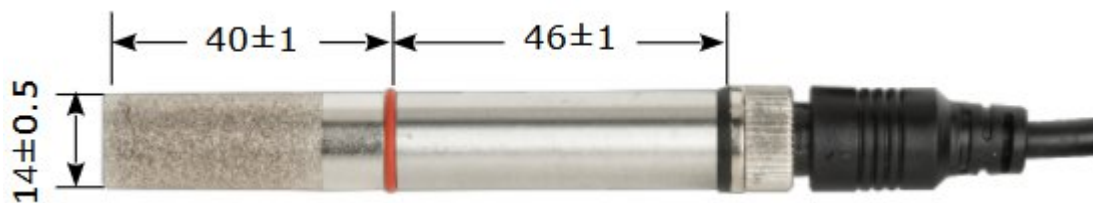

7 Installation

Make sure that all components listed below are included in your package.

Qty	Description	Item No.
1	S040 Atmospheric Sensor	S654 0400
1	L-shaped mounting bracket	No
1	5 m M12 cable with open ends	No
1	Quick Start Guide	No

The shipment includes an L-shaped mounting bracket, which allows the product to be mounted on any smooth plane.

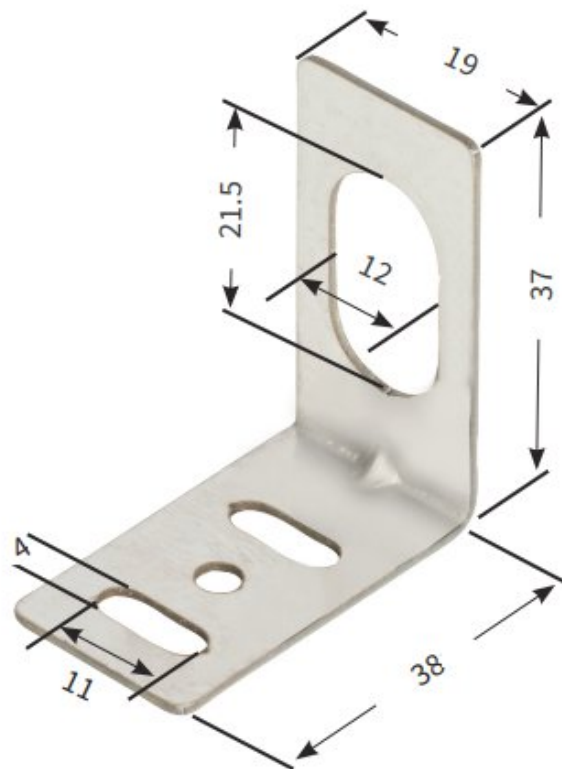

Installation bracket (Unit: mm)

Material: SS304
Thickness: 1 mm



ATTENTION!

Wrong measurement is possible, if the atmospheric sensor is not installed correctly.

7.1 Electrical Connection

The S040 is supplied with a 5-meter cable. The M12 connector on the cable is used to connect to the S040, and the open end of the cable is used to connect to the customer's equipment.

Cable connection (Modbus)

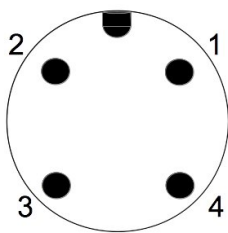

Pin	Color	Assignment
1	Green	Modbus data -
2	Black	Negative supply voltage
3	Red	Positive supply voltage
4	Yellow	Modbus data +



ATTENTION!

Do not screw the M12 connector using excessive force, as this may result in damage to the connecting pins.

7.2 Wiring Diagram

Modbus/RTU (RS-485) wiring diagram

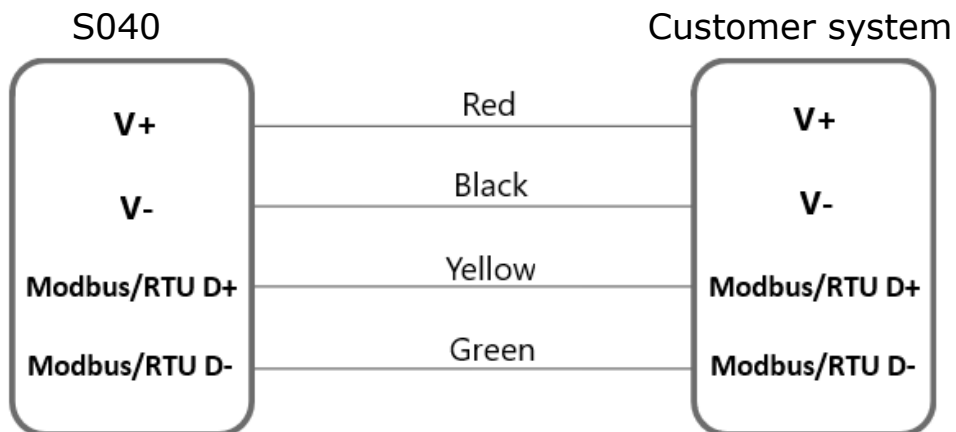

8 Modbus Communication

8.1 Default Setting

Mode: RTU

Baud rate: 19200

Device address: Last two digits of serial number

Framing / parity / stop bit: 8, N, 1

Response time: 5 second

Response delay: 100 ms

8.2 Protocol Frame

8.2.1 Read-Holding Register

The function code of read-holding register is 03.

The request frame format is as follows:

Address	Function Code	Register Address	Number of Registers	CRC16
1 byte	1 byte	2 bytes	2 bytes	2 bytes

The response frame format is as follows:

Address	Function Code	Data Length	Data	CRC16
1 byte	1 byte	1 bytes	Number of Registers ×2 bytes	2 bytes

Example:

Address of read-holding register: 64

The data sent: 01 03 00 64 00 02 85 D4

The data received: 01 03 04 41 3B 33 33 CB 27

8.2.2 Write-Holding Register

The function code of write-holding register is 06.

The request frame format is as follows:

Address	Function Code	Register Address	Data	CRC16
1 byte	1 byte	2 bytes	2 bytes	2 bytes

The response frame format is as follows:

Address	Function Code	Data Length	Data	CRC16
1 byte	1 byte	1 bytes	2 bytes	2 bytes

Example:

Address of write-holding register: 7

The data sent: 01 06 00 07 00 02 B9 CA

The data received: 01 06 00 07 00 02 B9 CA

8.2.3 Settings Save

After modifying the settings, you must send a **save** command to save changes; otherwise, the changes will be lost when you turn off the S040.

save:

Take the Modbus address of 1 as an example:

The data sent: 01 06 00 12 00 01 E8 0F

The data received: 01 06 00 12 00 01 E8 0F

8.3 Register

Register Address	Description	Register NO.	Data Type	R/W	Value
7	Slave address	1	Unsigned short	R/W	1 ~ 255
9	Baud rate	1	Unsigned short	R/W	03: 1200 bps 04: 2400 bps 05: 4800 bps 06: 9600 bps 07: 14400 bps 08: 19200 bps 09: 38400 bps 0A: 56000 BPS 0B: 57600 bps 0C: 115200 bps
18	Save	1	Unsigned short	R/W	1: Save the setting
79	Serial NO.	2	Unsigned int	R	
82	Data pattern	1	Unsigned short	R/W	0: Command mode 1: Active sending mode
83	Active sending mode interval	2	Float AB CD	R/W	
85	Active send mode start register	1	Unsigned short	R/W	
86	Active send mode registers number	1	Unsigned short	R/W	
87	Protocol version	2	Float AB CD	R/W	
89	Software version	2	Float AB CD	R/W	
91	Hardware version	2	Float AB CD	R/W	
93	Date of production	2	Float AB CD	R/W	

Register Address	Description	Register NO.	Data Type	R/W	Value
98	Device type	2	Float AB CD	R/W	
100	Temperature	2	Float AB CD	R	Unit: °C
102	Humidity	2	Float AB CD	R	Unit: % RH
104	Atmospheric pressure	2	Float AB CD	R	Unit: KPa
108	Altitude	2	Float AB CD	R	Unit: m

9 Calibration

The instrument is calibrated ex work. Its accuracy is regulated by the on site conditions, parameters like oil, high humidity or other impurities can affect the accuracy. It is recommended to calibrate the instrument at least once per year. The calibration is excluded from the instruments warranty. For this please contact the manufacturer.

10 Maintenance

To clean the Atmospheric Sensor and its accessories it is recommended to use a moist cloth only.



ATTENTION!

Do not use isopropyl alcohol to clean the Atmospheric Sensor and its accessories!

11 Disposal of Waste



Electronic devices are recyclable material and do not belong in the household waste.

The Atmospheric Sensor, the accessories and its packings must be disposed according to your local statutory requirements. The dispose can also be carried by the manufacturer of the product, for this please contact the manufacturer.

SUTO iTEC GmbH

Grißheimer Weg 21
D-79423 Heitersheim
Germany

Tel: +49 (0) 7634 50488 00
Email: sales@suto-itec.com
Website: www.suto-itec.com

SUTO iTEC (ASIA) Co., Ltd.

Room 10, 6/F, Block B, Cambridge Plaza
188 San Wan Road, Sheung Shui, N.T.
Hong Kong

Tel: +852 2328 9782
Email: sales.asia@suto-itec.com
Website: www.suto-itec.com

SUTO iTEC Inc.

5460 33rd St SE
Grand Rapids, MI 49512
USA

Tel: +1 (616) 800-7886
Email: sales.us@suto-itec.com
Website: www.suto-itec.com

SUTO iTEC (Thailand) Co., Ltd.

91/66 Suwinthawong Rd,
Minburi Bangkok 10510
Thailand

Tel: +66 (0)2108 9658
Email: sales.th@suto-itec.com
Website: www.suto-itec.com